

# EP-M1250

Nine Laser Large Format  
Metal Additive Manufacturing System



# EP-M1250

Using MPBF (Metal Powder Bed Fusion) technology, EP-M1250 is using a larger building envelope and nine-laser system to ensure a high efficiency production. The precise positioning and innovative area splicing control technology offers uniformity and stability throughout the whole printing phase.

The system can operate with various metal powders such as titanium, aluminum and nickel-based alloys, maraging steel, stainless steel, chrome cobalt alloys and other materials. It is suitable for the direct manufacturing of large size, high-precision and high-performance parts in the aerospace, aviation, automotive and machinery industry.

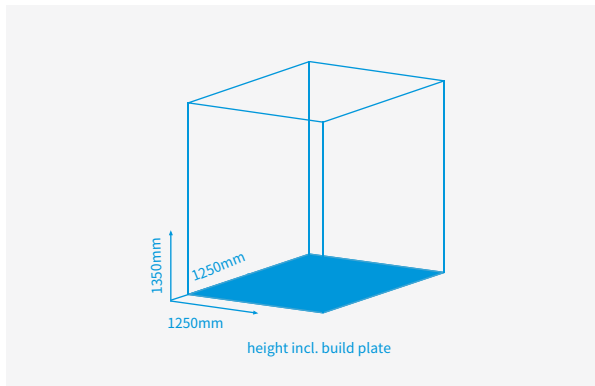

## « RELIABLE & STABLE

- Tightly sealed build chamber maintains oxygen concentration  $\leq 100$  ppm and a stable pressure during printing.
- Environment and gas source state real-time monitoring, safe and reliable.

## « HIGH EFFICIENCY & PRODUCTIVITY

- Printing of mass-individualized parts in the 2136 Liter build chamber.
- Each of the nine lasers covers its own area for maximum efficiency.
- Bi-directional powder re-coating method leads to reduced re-coating time.

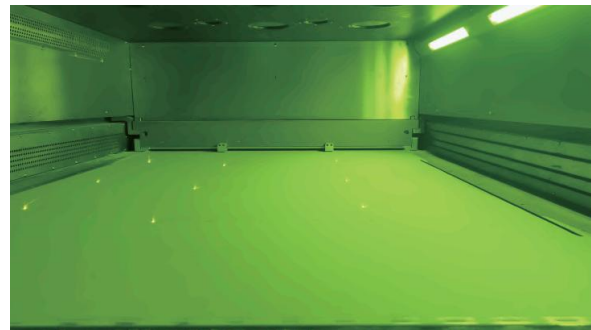

## » HIGH QUALITY

- Excellent high beam quality ( $M2 \leq 1.1$ ).
- Printed parts' density > 99.9%, deviation in parts' mechanical properties < 5%.
- The optimized gas flow design ensures efficient removal of smoke and splashes as well as achievement of uniform and consistent full size printing.
- The strict calibration ensures the consistency between parts and batches.

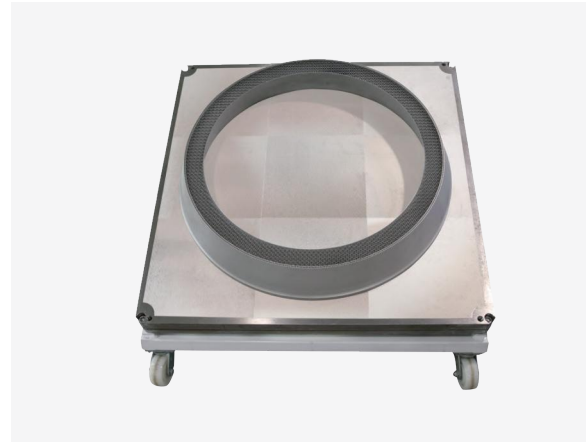

## « EASY OPERATION

- Friendly user interface with fully automatic one click printing function.
- Two-stage filtration, which can use blow back function to remove the fume, equipped with permanent filter element.
- The build job information is displayed in real time with traceable printing parameters report.

## » PERFECT AFTER-SALE SERVICE

- We support our customers with technical consulting services, including data evaluation, application development.
- Assisting our customers in new material parameter development, existing parameter packages are provided free of charge.
- Free equipment installation and maintenance during warranty period, full set of technical training is provided.



# EP-M1250

## PARAMETER

Machine Model	EP-M1250
Build Volume (X x Y x Z) (height incl. build plate)	1250 x 1250 x 1350 mm (49.21 x 49.21 x 53.15 in)
Optical System	Fiber Laser 9 x 500 W / 700 W / 1000 W
Spot Size	70 - 120 $\mu\text{m}$
Max Scan Speed	8 m/s
Layer Thickness	20 - 120 $\mu\text{m}$
Theoretical Printspeed	Up to 370 $\text{cm}^3/\text{h}$
Material	Titanium Alloy, Aluminum Alloy, Nickel Alloy, Maraging Steel, Stainless Steel, Cobalt Chrome, Copper Alloy, etc.
Substrate Heating	Substrate Heating Temperature 200 $^{\circ}\text{C}$
Power Supply	380 V, 100 A, 40 kW, 50 / 60 Hz
Gas Supply	Ar / N <sub>2</sub>
Oxygen Content	$\leq 100$ ppm
Dimension (W x D x H)	9000 x 4800 x 6300 mm
Weight	50000 kg
Software	EPControl, EP Hatch
Input Data Format	STL or other Convertible File

Notice: Eplus3D reserves the right to explain any alteration of the specifications and pictures.